

156 engine - dismantle and re-build following operation 1004e10 - wash and check dismantled parts - re-fit cylinder head and oil sump - does not include repairs to cylinder head and auxiliary unit 1004E20

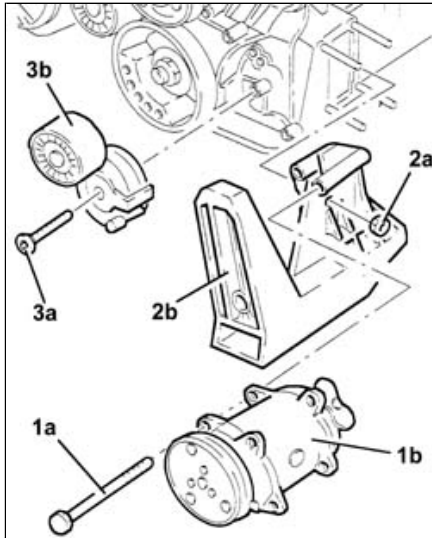

Dismantling ([Reassembling](#))

Rotate the engine through 180° on the overhauling stand.

1. Undo the bolts (1a) and remove the air conditioning compressor (1b).
2. Undo the bolts (2a) and remove the timing side rigid power unit support (2b).
3. Undo the bolt (3a) and remove the engine components single drive belt automatic tensioner (3b).

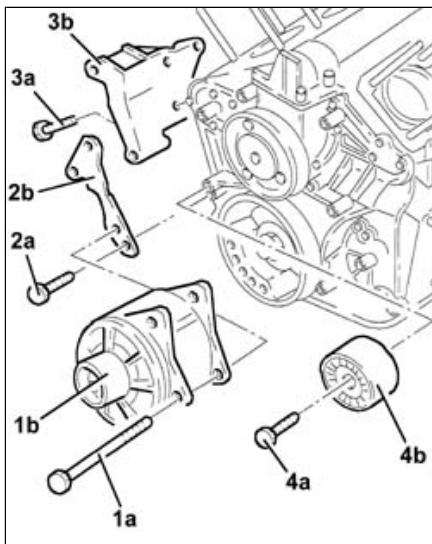

1. Undo the bolts (1a) and remove the alternator (1b).
2. Undo the bolt (2a) and remove the alternator rear bracket (2b).
3. Undo the bolts (3a) and remove the alternator mounting (3b).
4. Undo the bolt (4a) and remove the engine components drive belt fixed tensioner (4b).

1. Undo and remove the engine oil filter.
2. Remove the water-oil heat exchanger complete with pipes.
3. Undo the bolts (3a) and the nuts (3b) and remove the oil filter mounting and intermediate shaft (3c).
4. Remove the gasket.

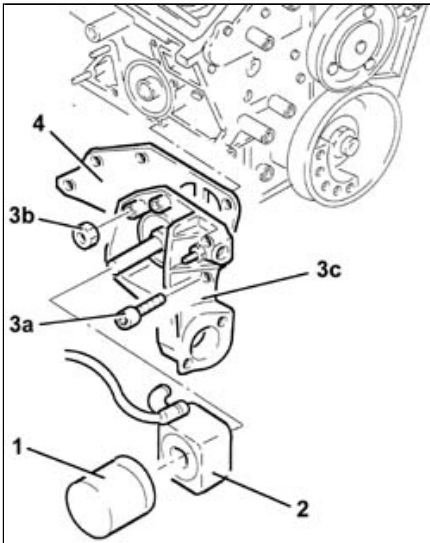

1. Remove the manifold for coolant return to the pump.

2. Undo the bolt (2a) and remove the knock sensor (2b).

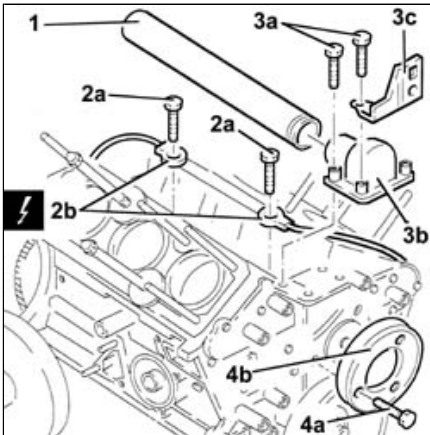

3. Undo the bolts (3a) and remove the water pump cover (3b) and bracket (3c).

4. Undo the bolts (4a) and remove the water pump drive pulley (4b).

1. Undo the bolts (1a) and remove the water pump (1b).

2. Remove the water pump gasket.

3. Fit the tool.

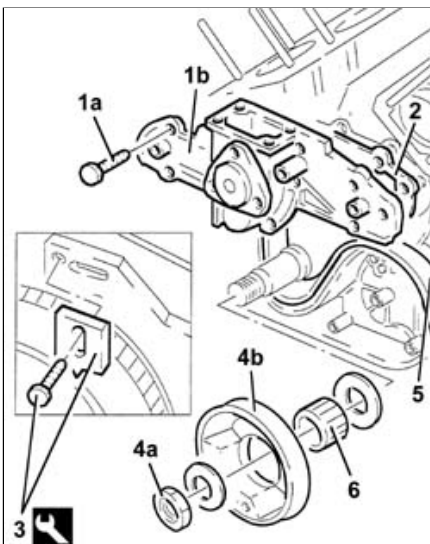

4. Undo the nut (4a) and remove the single drive belt (4b).

5. Remove the timing drive belt.

6. Remove the timing belt drive pulley.

Rotate the engine through 180° on the overhauling stand.

	Name	Connector
2b	Detonation sensor - 1	k50
	Name	Connector
2b	Knock sensor - 2	k51

	Name	Country
3	Counter-torque	1.820.624.000

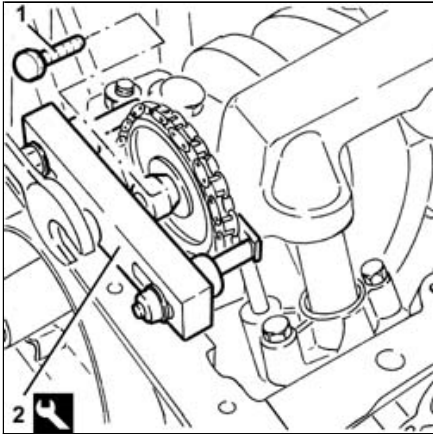

1. Undo the bolt fixing the oil pump chain drive to the oil pump.
2. Move aside the chain drive from the oil pump using the tool.

	Name	Country
2	Extractor	1.860.954.001

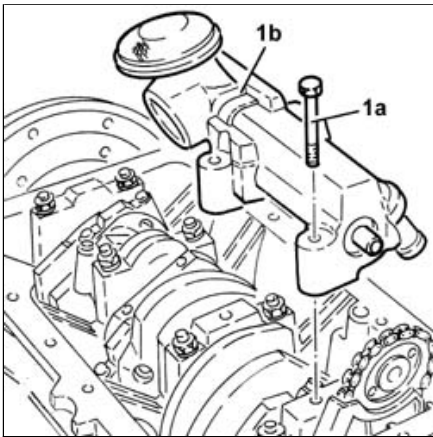

1. Undo the bolts (1a) and remove the complete oil pump (1b).

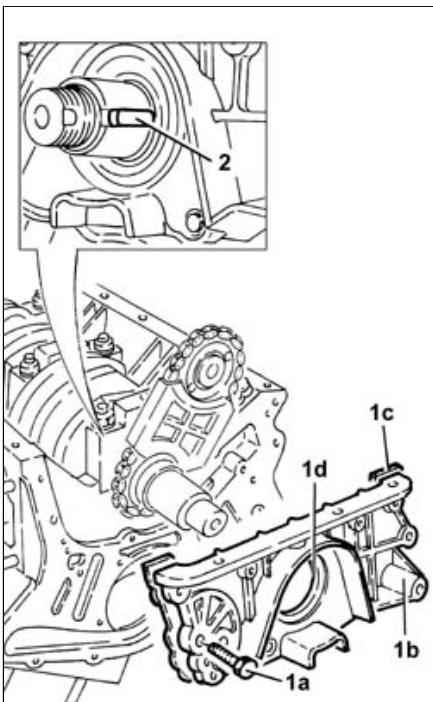

1. Undo the bolts (1a) and remove the engine block front cover (1b) complete with gasket (1c) and the crankshaft front oil seal (1d).
2. Remove the crankshaft key using a suitable drift.

1. Remove the oil pump drive chain.
2. Undo the bolt (2a) and remove the connector (2b) for engine oil delivery to the engine block.

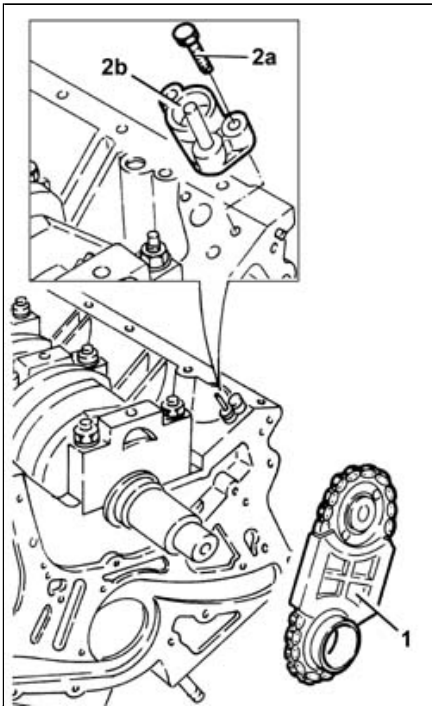

1. Undo the bolts (1a) and remove the engine flywheel (1b).

2. Remove the tool.

	Name	Country
2	Counter-torque	1.820.624.000

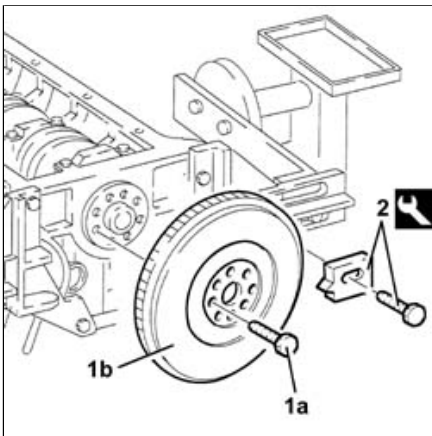

1. Fit the tool.

	Name	Country
1	Flange	1.820.618.000

Turn the crankshaft to gain access to the big end bearing cap bolts on the right bank.

2. Undo the nuts (2a) and remove the big end bearing caps (2b) complete with bearing shells (2c) from the right bank.

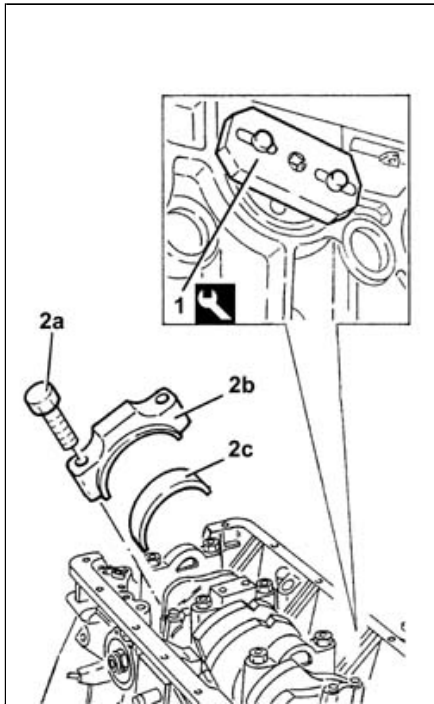

Rotate the engine through 180° on the overhauling stand.

1. Remove the tools from the right bank.

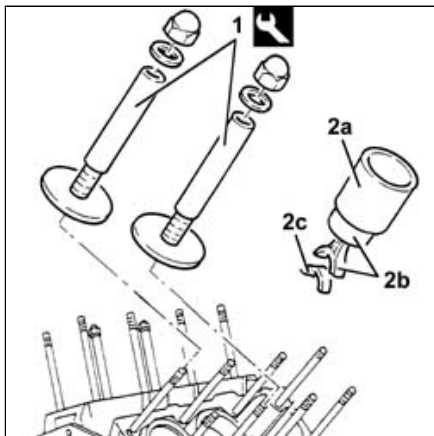

2. Remove the cylinder liners (2a), the connecting rod-piston assemblies (2b) and the big end bearings (2c) from the right bank.

Separate the connecting rod-piston assemblies from their cylinder liners.

Do the same to remove the cylinder liners and connecting rod-piston assemblies of the left bank.

Remove the tool.

	Name	Country
1	Liner/bore holder	1.820.279.000

Rotate the engine through 180° on the overhauling stand.

Check that the crankshaft end float is within the recommended values using a magnetic base fitted with a dial gauge.

	Measurement	Value

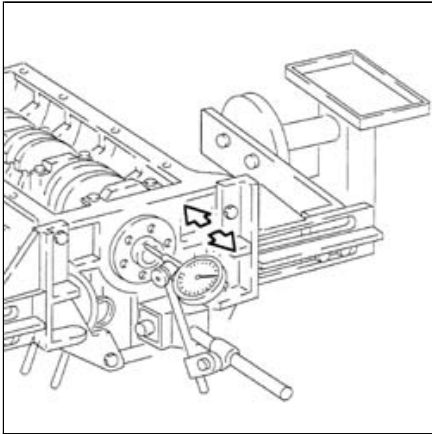

	End float (mm)	0.080 - 0.265
--	----------------	---------------

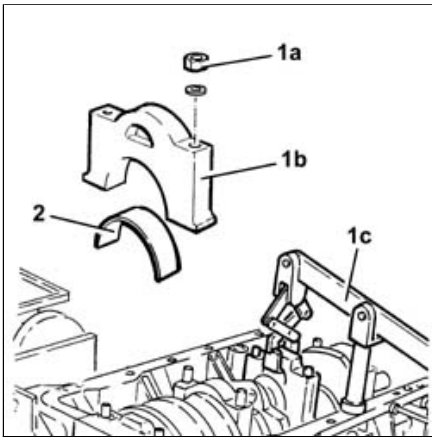

1. Undo the nuts (1a) and remove the front and central main bearing caps (1b) using a suitable tool (1c).
2. Remove the half-bearings.

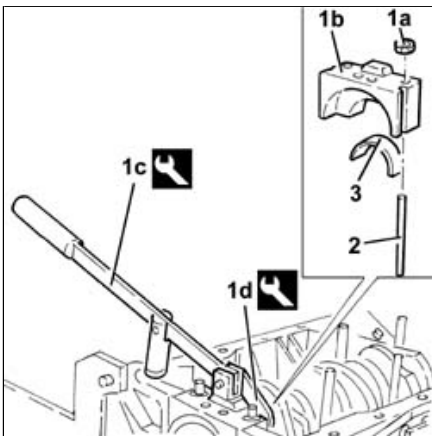

1. Undo the nuts (1a) and remove the rear main bearing cap (1b) using the tools (1c) and (1d).

	Name	Country
1c	Lever	1.821.006.001
	Name	Country
1d	Extractor	1.821.006.002

2. Remove the rubber seals.
3. Remove the half-bearing.
1. Remove the crankshaft.
2. Remove the crankshaft rear oil seal.
3. Remove the half-bearings.
4. Remove the thrust washers.
5. Remove the piston cooling oil jets from the engine block.

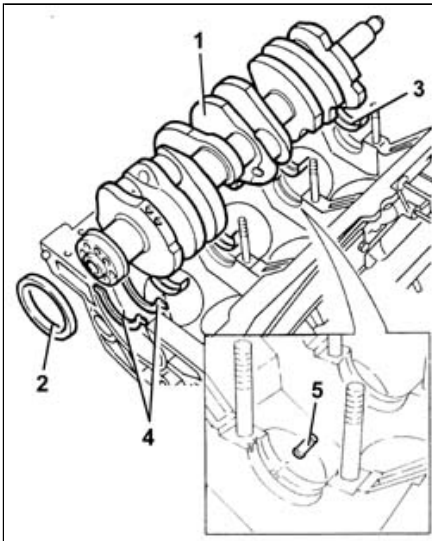

- **1028H60 piston, pin set - replace**

- **1084B18 engine oil pump, removed - check at bench**

Drill and remove the water/oil sealing plugs from the crankcase to allow washing.

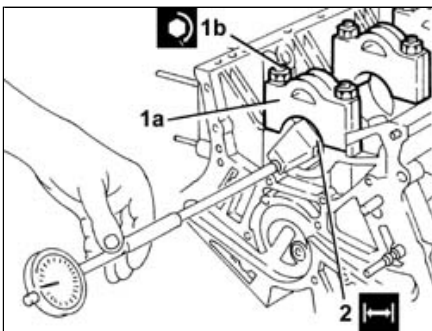

Reassembling ([Dismantling](#))

Wash the dismantled components.

Fit the water/oil sealing plugs in the crankcase, using suitable fitting tools.

Lubricate all the components for the mechanical couplings using engine oil.

Check that the planarity of the cylinder head support surface is within the recommended values; if this is not the case, regrind the cylinder head support surface.

	Measurement		Value
-	Flatness of cylinder head supporting surface (mm)		< 0.1

Measure the cylinder liner diameter and check that it is within the specified values. If this is not the case, replace the cylinder liners/bores.

	Measurement		Value
-	Inner diameter (mm)	Category B	87.995 - 88.004
Category C	88.005 - 88.014		
Classe A	87.985 - 87.994		

Check that the ovality of the cylinder liners is within the recommended values.

	Measurement		Value
-	Ovalization (mm)		< 0.01

1. Fit the main bearing caps (1a) and tighten the nuts (1b) to torque.

	Fastening	Component	Ø	Value (daNm)
1b	Nut	MAIN BEARING CAPS	M12	(Engine crankcase side) 2.5 + 79°

Use the special tool for the angular tightening of the main bearing cap nuts.

	Name	Country
-	Protractor	1.860.942.000

2. Check that the diameter of the bearing seats is within the recommended values.

	Measurement		Value
2	Main bearing seat diameter (mm)	Category B	63.663 ÷ 63.669
	Category C		63.669 ÷ 63.675
	Classe A		63.657 ÷ 63.663

Check that the crankshaft lubrication ducts are free from deposits.

Check that the diameter of the main journals is within the recommended values; if this is not the case, replace the crankshaft.

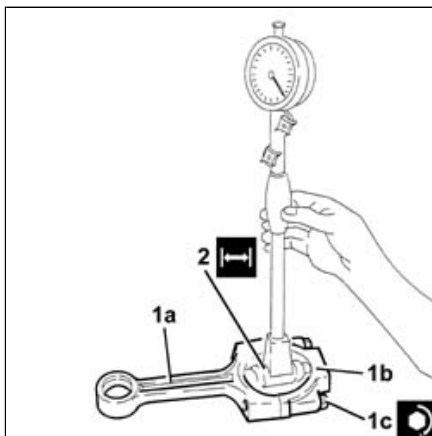

	Measurement		Value
-	Main bearing journal diameter (mm)	Category B	59.967 ÷ 59.973
	Category C		59.961 ÷ 59.967

Classe A	59.973 ÷ 59.979
----------	-----------------

Check that the diameter of the crankpins is within the recommended values; if this is not the case, replace the crankshaft.

	Measurement		Value
-	Crankpin diameter (mm)	Category B	51.980 ÷ 51.990
Classe A	51.990 ÷ 52.000		



Check that the inner diameter of the small end bushes is within the recommended limits; if this is not the case, replace the connecting rod.

	Measurement		Value
-	Inner diameter (mm)		20.005 - 20.015

Check that the outer diameter of the gudgeon pins is within the recommended values; if this is not the case, replace the worn gudgeon pins.

	Measurement		Value
-	Outer diameter (mm)	Category B	21.997 - 22.000
Classe A	21.994 - 21.997		

Fit the seals in the cylinder liner/bore and check that the opening between the ends is within the recommended values; if this is not the case, replace the piston seals.



	Measurement		Value
-	1° sealing ring gap (mm)		0.40 - 0.65
	Measurement		Value
-	2° sealing ring gap (mm)		0.40 - 0.65
	Measurement		Value
	Scraper ring gap		

-	(mm)	0.40 - 0.60
---	------	-------------

Check that the outer diameter of the pistons is within the recommended values. if this is not the case, replace the piston complete with seals and gudgeon pin.

	Measurement		Value
-	Outer diameter (mm)	Category B	87.935 - 87.945
		Category C	87.945 - 87.955
		Classe A	87.925 - 87.935

Check that the endfloat between compression rings and their seats is within the specified values.

	Measurement		Value
-	1st° sealing ring end float (mm)		0.035 - 0.070
	Measurement		Value
-	2° sealing ring end float (mm)		0.035 - 0.070
	Measurement		Value
-	Oil scraper ring end float (mm)		0.025 - 0.060

1. Fit the caps (1b) on the connecting rods (1a) and fix them tightening the bolts (1c) to torque.

	Fastening	Component	Ø	Value (daNm)
1c	Bolt	BIG END BEARING CAPS	M9	1.9 ÷ 2.1 + 48? ÷ 52?

Use the tool for angular tightening of the connecting rod cap bolts.

	Name	Country

-	Protractor	1.860.942.000
---	------------	---------------

2. Check that the diameter of the big end is within the recommended values; if this is not the case, replace the connecting rods.

	Measurement	Value
-	Big end diameter (mm)	55.511 - 55.524

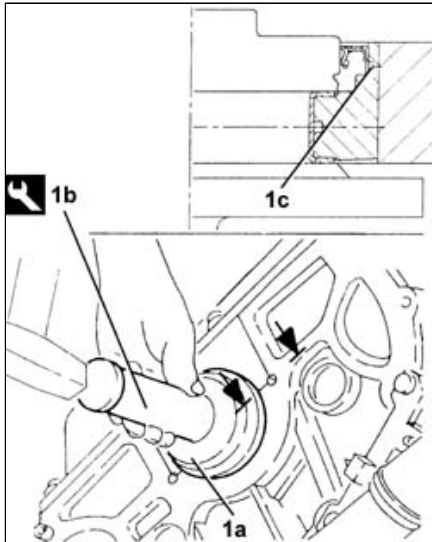

- **1084B18 engine oil pump, removed - check at bench**

- **1028H60 piston, pin set - replace**

Check that there are no signs of seizing on the flywheel ring gear teeth; if this is not the case, replace it.

Fit the piston cooling oil jets in the engine block.

Fit the thrust washers on the rear bearing support.



The lubrication ducts in the thrust washers are fitted facing the crankshaft shoulder.

Fit the main journal half-bearings in the cylinder block/crankcase.

Fit the crankshaft on the cylinder block/crankcase.

Thoroughly remove the sealant residues from the rear bearing cap seat, the small holes and the contact surfaces with the oil sump (only for car after engine no. 00709).



Thoroughly remove all traces of engine oil using heptane or a similar solvent.

Fit the main journal caps complete with half-bearings.





The main journal caps are numbered from 1 to 4 starting from the front of the engine.

Tighten the nuts for the bearing caps to the recommended torque using the special angular tightening tool.

	Fastening	Component	Ø	Value (daNm)
-	Nut	MAIN BEARING CAPS	M12	(Engine crankcase side) 2.5 + 79°
	Name		Country	
-	Protractor		1.860.942.000	

1. Fit the crankshaft rear oil seal (1a) using the tool (1b).

 The oil seal should be fitted in its housing so that it covers the small openings (1c).

	Name	Country
1b	Fitting tool	1.821.150.000

1. Apply the recommended sealant (1a) through holes (1b).

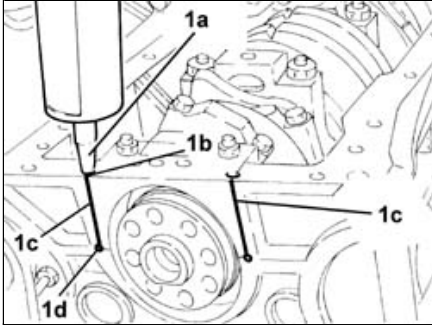

	Type	Component	Name	Qty.
-	Sealant	ENGINE MOUNT REAR GASKETS	LOCTITE 5900	-

 Check that the sealant emerges from the whole length of the contact area (1c) between the cap and the engine block and, (only for cars from engine no. 00709, from the holes (1d).



The oil sump should be fitted within 15 minutes of applying the sealant in the openings for the crankshaft rear support. If this is not the case, remove the edges of the sealant.

Rotate the engine through 180° on the overhauling stand.

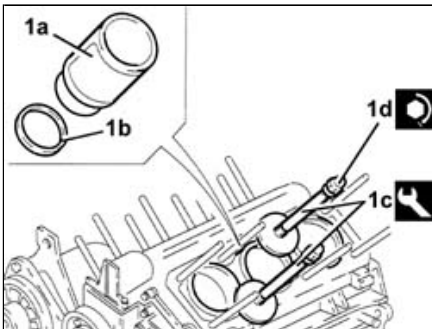



1. Fit the cylinder liners (1a) complete with compression rings (1b) in the engine block and lock them with tool (1c) tightening the nuts (1d) to a torque of 1.0 - 1.5 daNm.

	Name	Country
1c	Liner/bore holder	1.820.279.000

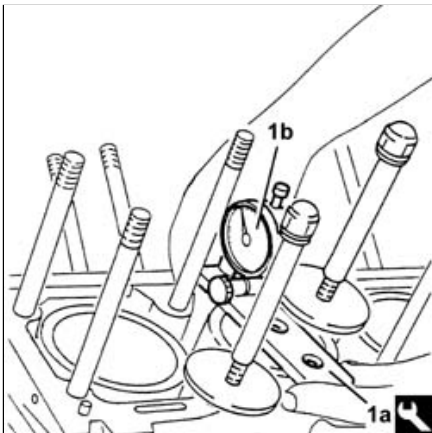
1. Measure the cylinder liner projection from the engine block surface using tool (1a) fitted with a dial gauge (1b) and check that it is within the specified values.



	Measurement	Value
1	Projection from cylinder block surface (mm)	0.01 - 0.06

	Name	Country
1a	Dial gauge mounting	1.825.003.000

1. Fit the connecting rod-piston assemblies (1a) complete with bearing shells (1b) in the cylinder liners, using a suitable tool (1c).

 The pistons are fitted with the arrow stamped on the crown facing the front of the engine.

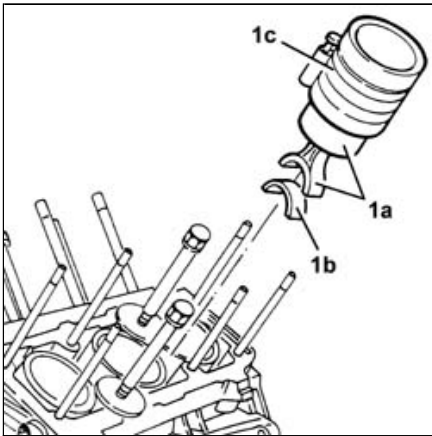

Rotate the cylinder block 180° on the overhaul stand.

1. Fit the tool.

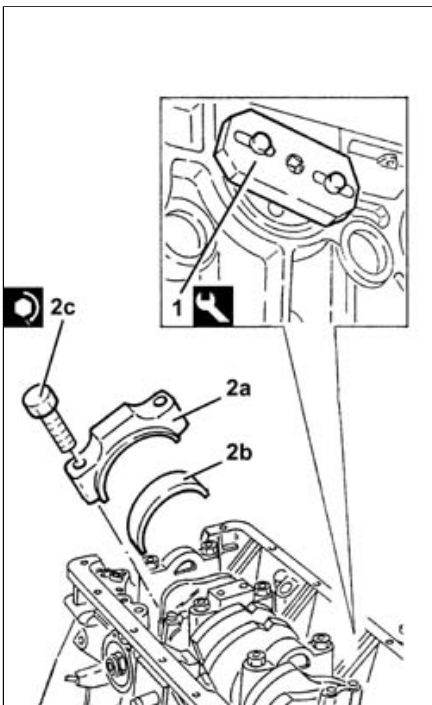

	Name	Country
1	Flange	1.860.815.000

2. Rotate the crankshaft as appropriate and fit the big end bearing caps (2a) complete with bearing shells (2b) and tighten the bolts (2c) to torque.

 The big end bearing caps have the number of the cylinder to which they belong on one side: when refitting, this number should be on the same side as the one on the small end.

	Fastening	Component	Ø	Value (daNm)
-	Bolt	BIG END BEARING CAPS	M9	$1.9 \div 2.1 + 48? \div 52?$

Use the tool for angular tightening of the connecting rod cap bolts.

	Name	Country
-	Protractor	1.860.942.000

Remove the tool.

	Name	Country
2c	Flange	1.860.815.000

Rotate the engine through 180° on the overhauling stand.

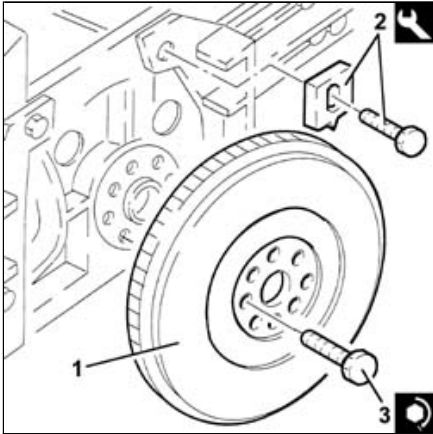

1. Fit the flywheel and fix it using its bolts, without tightening them.

2. Fit the tool.

	Name	Country
2	Counter-torque	1.820.624.000

3. Tighten the flywheel bolts to torque.

	Fastening	Component	Ø	Value (daNm)
3	Bolt	FLYWHEEL	M10	11.6 ÷ 12.9

Remove the tool.

	Name	Country
-	Counter-torque	1.820.624.000

Rotate the engine through 180° on the overhauling stand.

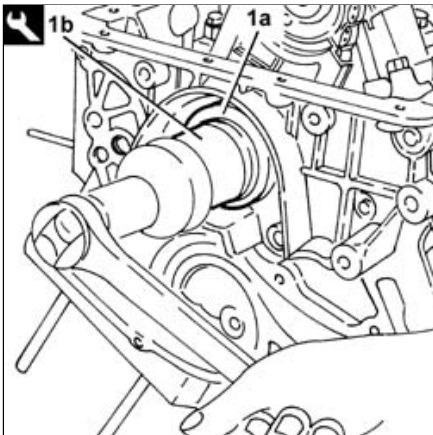

Fit the connector for engine oil delivery to the engine block, and tighten its bolt.

Fit the oil pump drive chain.

Fit the crankshaft key.

Fit the engine block front cover complete with gasket and fix it using the bolts.

Fit the complete oil pump and fix it using the bolts.

Tighten the bolt on the oil pump chain drive to torque.

	Fastening	Component	Ø	Value (daNm)
-	Bolt	ENGINE PUMP DRIVE CHAIN	M10	4.3 ÷ 5.3

1. Fit the crankshaft front oil seal (1a) using the tool (1b).

	Name	Country

1b	Fitting tool	1.860.949.000
----	--------------	---------------

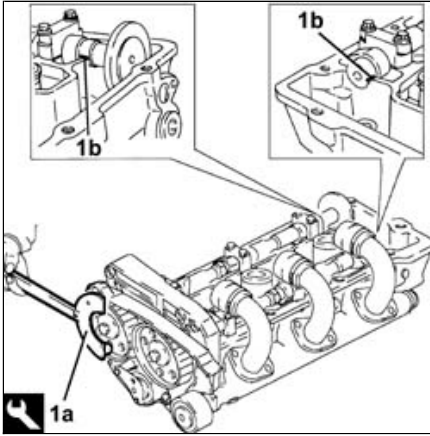

Apply the recommended sealant to the entire perimeter of the crankcase sump.



	Type	Component	Name	Qty.
-	Sealant	OIL SUMP	LOCTITE 5900	-

Fit the crankcase sump.

Tighten the sump bolts to torque.

	Fastening	Component	Ø	Value (daNm)
-	Bolt	OIL SUMP	M7	1.3 ÷ 1.6
	Fastening	Component	Ø	Value (daNm)
-	Bolt	OIL SUMP	M7	0.9 ÷ 1.2

Fit the rpm and timing sensor and fix it to the crankcase sump using the bolts.

Fit the engine components single drive belt fixed belt tensioner and fix it to the crankcase sump using the bolt.

Rotate the engine through 180° on the overhauling stand.

Fit the water pump complete with gasket and fix it to the engine block, tightening the bolts to torque.

	Fastening	Component	Ø	Value (daNm)
-	Bolt	COOLANT PUMP	M6	0.7 - 0.9

Fit the water pump cover and its bracket, and fix it using the bolts.

Fit the detonation sensors and fix them using the bolts.

Fit the manifold for coolant return to the pump.

Rotate the crankshaft until the piston of cylinder no. 1 is at T.D.C.

1. Before fitting the cylinder head, rotate the camshafts using the tools (1a) until the reference marks (1b) on the shafts line up with the cylinder head top surface.

--	--	--

	Name	Country
1a	Counter-torque	1.822.146.000

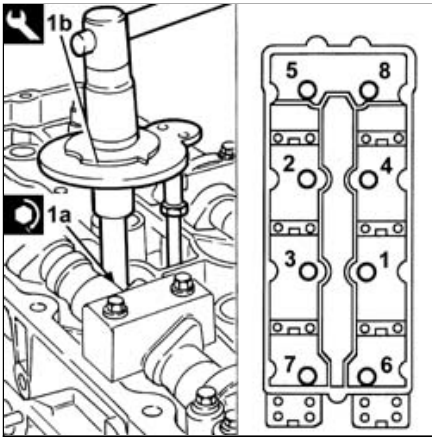

Remove the tool.

	Name	Country
-	Liner/bore holder	1.820.279.000

Fit the cylinder head centring bushes to the engine block.

Fit the new cylinder head gaskets.

The cylinder head gaskets are of the Astadur type.

The material from which they are made undergoes polymerization during engine operation, so they harden considerably during use.



In order for the polymerization process to take place it is necessary to:

keep the gasket in its sealed container until fitting

not lubricate or get oil on the gasket and the contact surfaces.

Position the cylinder heads on the engine block.

1. Tighten the nuts of the cylinder heads (1a) to torque using the tool (1b) for angle tightening.

Follow the order shown in the diagram for each tightening sequence.

The diagram shows the right cylinder head; the tightening order for the left cylinder head is symmetrical;

	Fastening	Component	Ø	Value (daNm)
1a	Nut	CYLINDER HEAD	M12	2.4 ÷ 2.6 + 240?

	Name	Country
1b	Protractor	1.860.942.000

1. Remove the camshaft caps 4 and 7 from the left cylinder head.

2. Remove the camshaft caps B and G from the right cylinder head.

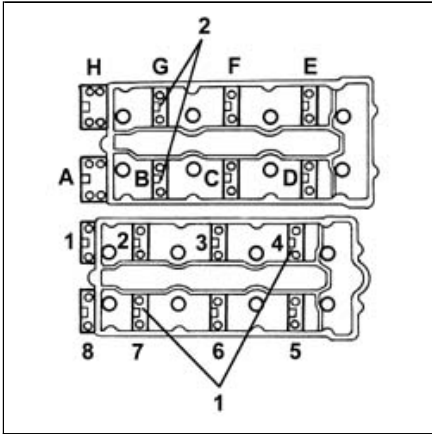

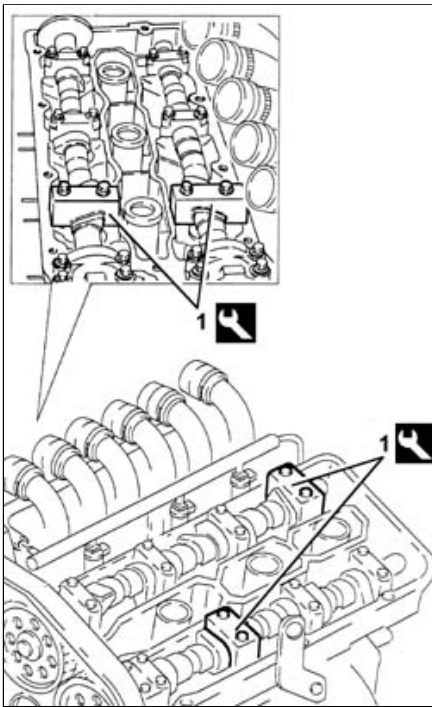

1. Fit the tool in place of the removed camshaft caps.

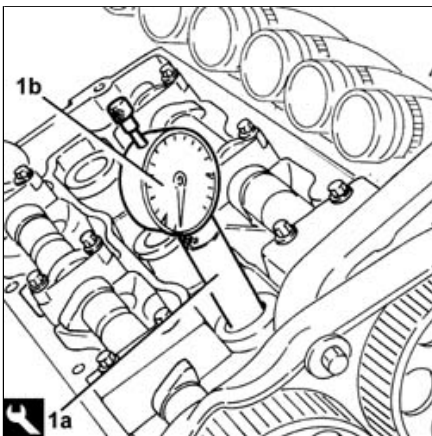

	Name	Country
1	Gauge	1.825.040.000

Slacken the bolts on the camshaft drive pulleys using the tool as counter-torque.



	Name	Country
-	Counter-torque	1.822.146.000

Fit the timing belt drive pulley.

Fit the fixed single drive belt tensioner and fix it with its bolt.

Fit the alternator mounting and fix it using the bolts.

Fit the alternator rear bracket and fix it with its bolts.

1. Fit the tool (1a), complete with dial gauge (1b), in the housing of the spark plug for cylinder no. 1.

--	--	--

	Name	Country
1a	Extension	1.825.013.000

Rotate the crankshaft, using small movements (in both directions), until the piston for cylinder no. 1 is at T.D.C. at the power stroke.

 Make sure that the last crankshaft rotation is in the direction of operation.

1. Fit the timing belt starting from the drive pulley and continuing in an anti-clockwise direction, making sure that the drive sections are firmly taut.

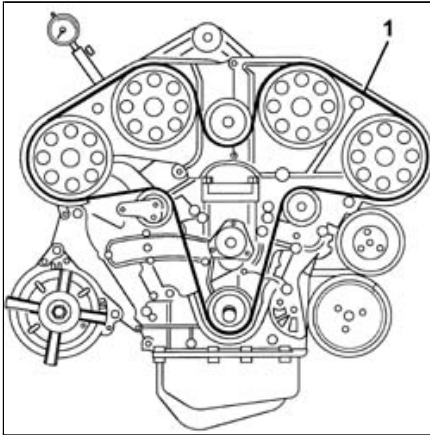

1. Fit the tool (1a) and secure it with the alternator bolt (1b) and the bolt (1c) to the water pump.

 The tool lug (1d) must press against the moving part of the timing belt tensioner.

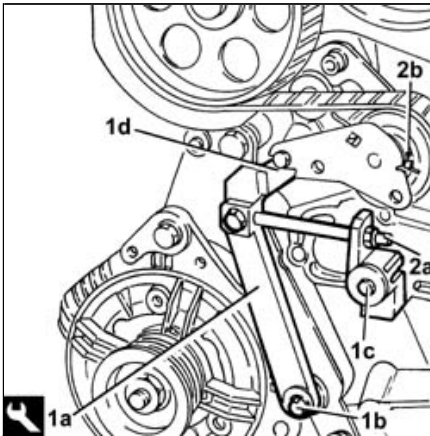



	Name	Country
1a	Belt tensioner	1.860.950.000

2. Adjust the nut (2a) of the belt tensioner tool until the moving reference on the belt tensioner (2b) is under the fixed reference.

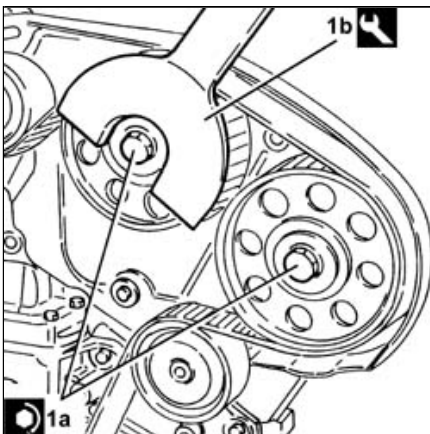
1. Tighten the bolts (1a) for the camshaft pulleys to torque using the tools (1b) for counter-torque.





	Fastening	Component	Ø	Value (daNm)
1a	Bolt	TIMING GEAR DRIVEN PULLEYS	M10	6.8 ÷ 8.4

	Name	Country

1b	Counter-torque	1.822.146.000
----	----------------	---------------

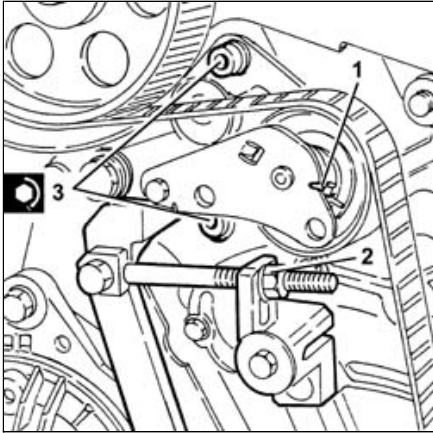
Remove the tool.



	Name	Country
-	Gauge	1.825.040.000

Fit the camshaft caps in place of the removed tool and fix them, tightening the bolts to torque.

	Fastening	Component	Ø	Value (daNm)
-	Bolt	CAMSHAFT CAPS	M8	(Cylinder head side) 1.8 ÷ 2.0

Rotate the crankshaft through two revolutions in its direction of rotation to allow the timing belt to bed in.

1. Check that the moving reference on the timing belt tensioner lines up with the fixed reference.
2. If the references do not line up, slightly discharge the tensioner acting on the tensioning tool nut and make sure that the references are aligned.
3. Tighten the timing belt tensioner bolts to torque.

	Fastening	Component	Ø	Value (daNm)
3	Bolt	MOBILE TIMING TENSIONER	M8	1.7 ÷ 2.1

Remove the tool.

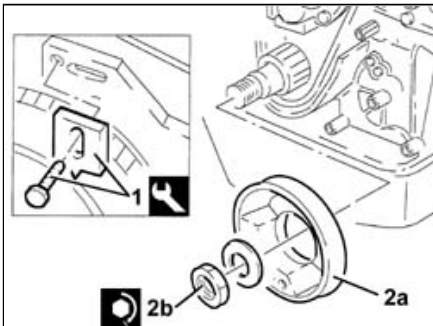

	Name	Country
-	Belt tensioner	1.860.950.000

1. Fit the tool.

	Name	Country
1	Counter-torque	1.820.624.000

2. Fit the single belt drive pulley (2a) and tighten the nut (2b) to torque.

	Fastening	Component	Ø	Value (daNm)
2b	Nut	CRANKSHAFT PULLEY	M28	20.0 - 24.7

Remove the tool.

	Name	Country
-	Counter-torque	1.820.624.000

Fit the water pump drive pulley and fix it using the bolts.

Fit the oil filter mounting and intermediate shaft complete with seal and fix it with the bolts.

Fit the water-oil heat exchanger complete with pipes.

Fit the oil filter.

Fit the single belt automatic tensioner.

Fit the power unit rigid support, timing gear side, and fix it using the bolts.

Fit the air conditioner compressor and fix it with its bolts.

Fit the tappet covers and fix them with their bolts.

Fit the exhaust manifolds and fix them using the nuts.

Fit the left exhaust manifold shield and fix it using the nuts.

Fit the oil level dipstick and fix it using the bottom nut and top bolt.

Fit the thermostat and fix it using the bolts.

Connect, to the thermostat, the coolant supply pipe to the water-oil heat exchanger.

Fit the ignition coils and fix them using the bolts.

Fit the bracket securing the timing cover and fix it using the bolts.

Connect the flexible pipe to the fuel distribution manifold rigid pipe.

Tighten the bolt joining the timing belt rear covers.

Fit the timing belt covers and fix them using the bolts.

Fit the single drive belt.

Push the single belt tensioner with a spanner to remove the belt tensioner retaining pin.

Place the electrical wiring back in its housing and fix it to the bands.

Connect the electrical connections to the ignition coils.

Connect the electrical connections to the injectors.

Fit the electrical wiring securing brackets to the rocker covers and fix them using the bolts.

Connect the electrical connection for the front knock sensor.

Connect the electrical connection for the air conditioning compressor.

Fit the left cylinder head ignition coils cover and fix it using the bolts.

Connect the earth lead to the left cylinder head tappet cover.

Connect the electrical connection to the engine coolant temperature sensor.

Connect the electrical connection to the combined sender unit for the coolant temperature gauge and overheating warning light.

Connect the electrical connection for the rear knock sensor (black).

Connect the electrical connection for the rpm and timing sensor (black).

Connect the electrical connection for the timing sensor (light blue).

Fit the complete intake chamber and fix it using the bolts.

Tighten the bands fixing the air intake ducts to the intake chamber.

Connect the condensation oil return pipe to the separator.

Connect the oil vapour recovery pipe.

Connect the electrical connection to the motorized throttle body actuator.

Connect the earth lead on the left cylinder head rocker cover.

- **1004D40 engine - position on stand and remove**